

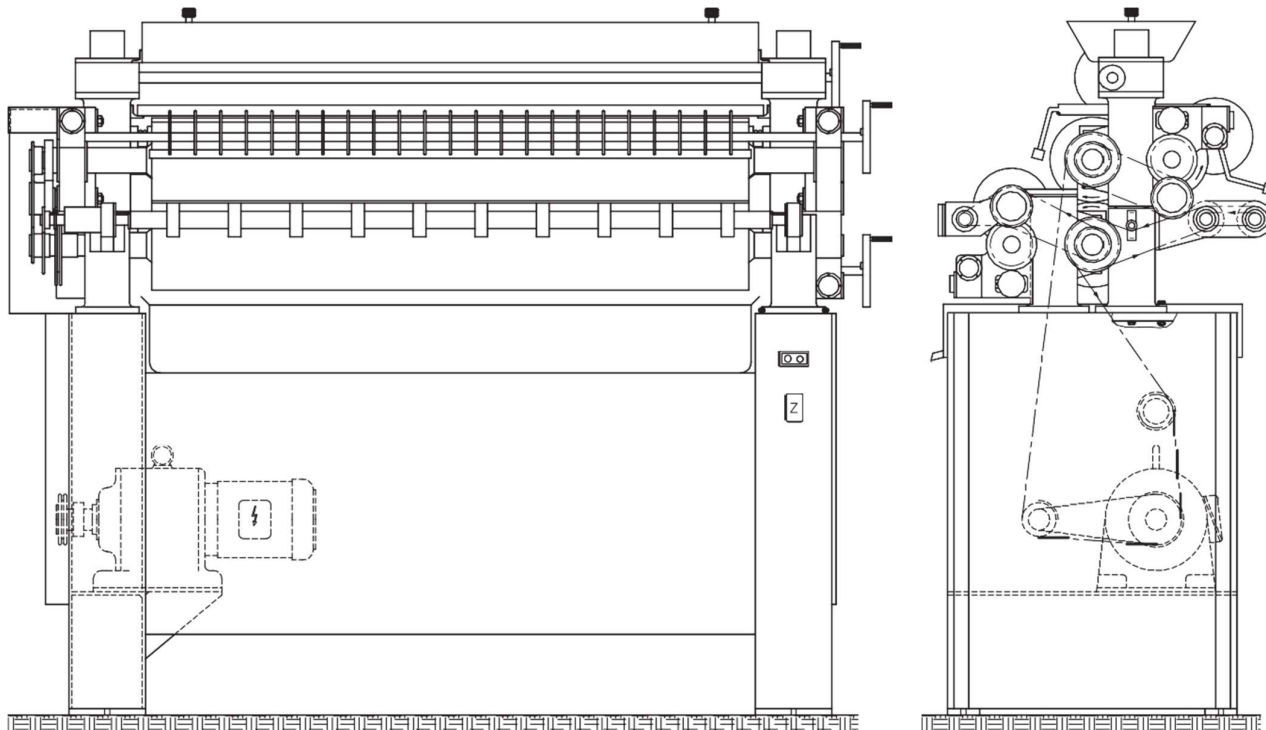

ADHESIVE APPLICATOR, TYPE NL

46.23/10.4.1



Purpose:

- for both-side glue spreading on flat wooden elements..

Main technical data

Useful working wide	800 ÷ 2200 mm	On request.
Max working thickness	80 mm	
Working speed	18 m / min	
• • •	• • •	